

Uniclass	EPIC
L413:P51	D13:X5
CI/SfB	
(31.4)	Xi

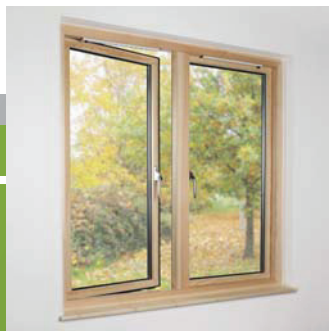

Alu-Timber

Merging Material Solutions

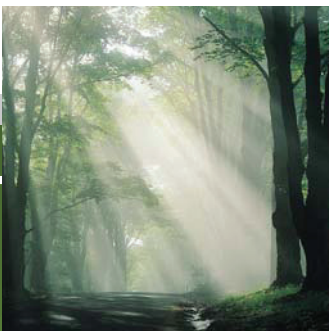



Alu-Timber

Merging Material Solutions

Creating sustainable, energy efficient buildings is a cornerstone of design. The facade is now a functional element to the building; a membrane which keeps the building warmer in the winter and cooler in the summer, reducing the need for additional energy from heating or air conditioning. The materials used must be sustainable, renewable and have a real end of life use.

Taking all current specification and building regulation demands into consideration, The Parkside Group Limited are pleased to launch Alu-Timber, a range of

aluminium/timber windows, doors and framing, that combines sustainably grown FSC or PEFC timbers with 100% recyclable aluminium.

“The Alu-Timber range of framing, windows and doors, merge material solutions: timber providing the thermal efficiency, aluminium the protection.”

Timber is a non-conductive material, minimising heat loss and, by using high performing glass, the lowest U-values are achievable. To protect, aluminium gives the timber facade a standard 25 year performance guarantee. Alu-Timber gives the specifier benefits: low U-values to achieve current legislation as well as reassurance for the client that the facade will last, with minimal maintenance.

Timber

Option 1 – Engineered Timber

Technological advances mean that traditional softwoods are now processed and are classed as Engineered Timbers. The Engineered Timber is laminate bonded, which means that knots and deformities are removed from the centre of the section. The laminating gives

“Creating a Palette of Textured Timber Colours”



“Alu-Timber merges material solutions, creating facades that meet today’s efficiency demands.”

the timber about seven times the stress factor of solid oak and increases its stability by 30-40% compared to its solid equivalent. Three layers of timber are bonded together, each layer of the timber is finger jointed along its length. This method of processing creates dimensional stability by eliminating bowing and twisting, creating higher deflection loads. This method of timber treatment creates minimal wastage as well as an aesthetically pleasing smooth wood grain finish.

Engineered timber comes from abundant forests which are forestry farmed sustainable sources, compliant with FSC, PEFC accreditation. Engineered timbers are available in Softwood, Larch and Eucalyptus.

Option 2 – Traditional Solid Timbers

For specific projects, other timbers, with the same accreditation, are available such as Oak and Ash. Due to their strength, these woods are classed as solid timbers and merely treated with a water soluble lacquer to ensure their design life.

Aluminium

Aluminium with its cradle to cradle lifecycle, recyclability and longevity, is the ideal material to give timber a leading edge. Its high strength to weight ratio means that less material can be used to give the timber facade its 25 year guarantee. At its end of life the aluminium is 100% recyclable and can be used again and again with no loss to its form or quality.

Alu-Timber: framing, windows, doors



The Heart of Success: Alu-Timber Construction

Alu-Timber A True Composite

Aluminium is a tried and tested facade material, providing a well known realm of design solutions. By taking this renowned industry design, fabrication and installation expertise and merging it with the very latest timber innovation, Alu-Timber provides the market with windows, doors and framing that can be fabricated and installed as aluminium facade products. Using these tried and tested aluminium construction methods, Alu-Timber provides reassurance for clients, specifiers and building end users.

Creating longevity is the whole ethos of Alu-Timber, protecting the timber to the external with aluminium throughout the facade. To construct Alu-Timber corner joints, the timber is cut at 45° then sealed, so there is no exposed raw timber joint, creating reassurance for the specifier that rot will not set in. Dowel pins are then used to secure the corner. The aluminium is made traditionally, with cleats and 45° mitres. The aluminium has a nosing which fits into a groove within the timber frame; the two materials are simply pressed together to create Alu-Timber.

Timber and aluminium are two distinct materials. Over time, expansion and contraction occurs at different rates; concern should highlight the jointing of these materials. Alu-Timber is bonded together with a flexible seal, creating a true solid composite, with designed-in features to cater for any differential movement.



Alu-Timber: Combinations

The Alu-Timber range includes casement, tilt and turn windows and an open-in and open-out door. Due to the superior jointing of Alu-Timber, it has inherently high deflection loads. Alu-Timber can therefore be used as a window walling suite up to storey height, creating modular framing systems with opening windows and doors.



Combinations...

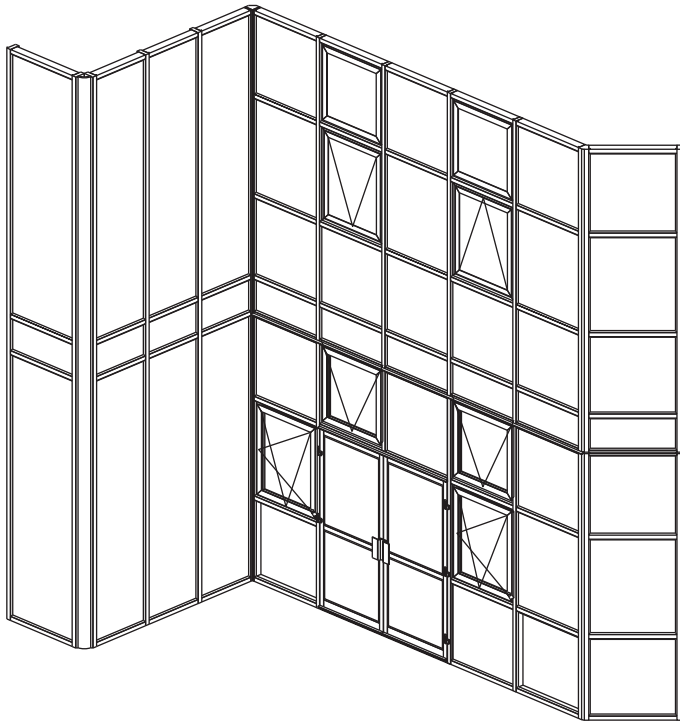

Alu-Timber Framing
A range of mullion and transoms to provide framing up to 4000mm high at 1000mm centres.

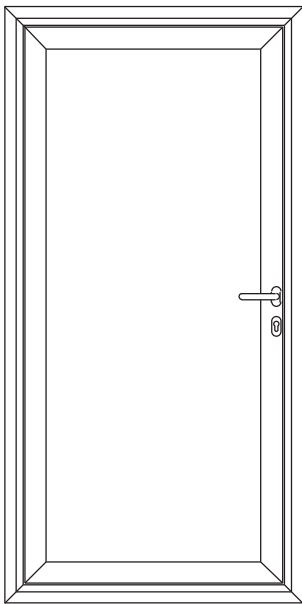

Alu-Timber Doors
Open-in, Open-out and Double Doors.

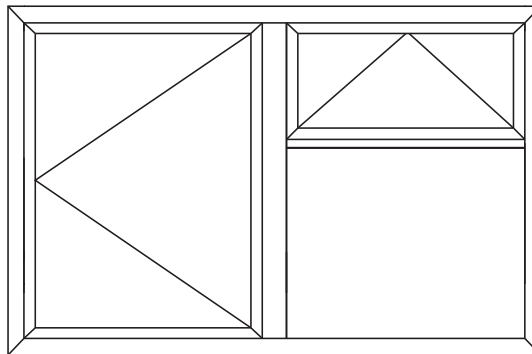

Alu-Timber Casement
A range to provide side, top hung or fixed windows.

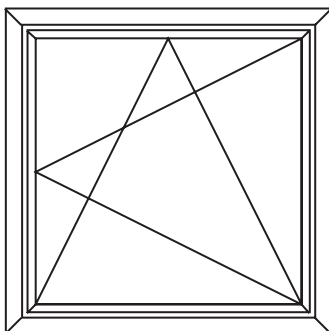

Alu-Timber Tilt & Turn
Tilt and turn windows, with options for larger sizes providing french casement option.

Alu-Timber Performance

Glazing & Thermal Performance

To meet current building regulations, the glazing is 24mm or 28mm with the capacity for increased glazing sizes on a project specific basis. These two sizes offer a cost effective double or triple glazed solution, creating U-values as low as 1.43W/m²K for a CEN sized window. This standard U-value, depending on the window configuration, can be lower. The Parkside Group Limited offers project-by-project U-value calculations to suit your SBEM requirements.

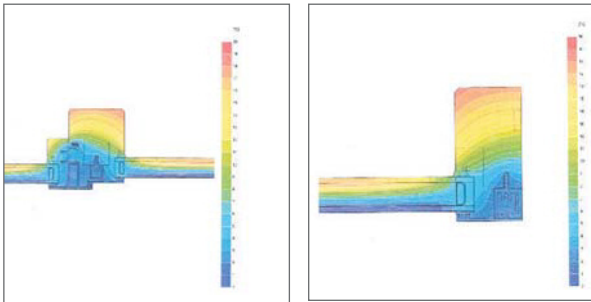

Performance Standards

The Alu-Timber range has exceeded the requirements of BS 6375 & PAS 23 achieving 600Pa for air, 600Pa for water, and wind resistance to 2400Pa. Security concerns are alleviated as Alu-Timber has passed BS7950 for windows and PAS 24 for the door sets. Wind loadings and calculations are undertaken to the latest international standards.

Size & Weight Limitations

	Max Width	Max Height	Max Weight
Framing*	1000mm (Centres)*	4000*	
Top-hung	1300mm	1500mm	40kg
Side-hung	900mm	1500mm	30kg
Tilt & Turn	1310mm	2200mm	

*Subject to Wind Loading Calculations

Specification

The Parkside Group Limited, has a Nationwide team of architectural advisors who specialise in providing architects and specifiers with project support, calculations and NBS specifications. The relevant NBS clauses are:

- H11 Curtain Walling
- L10 Windows/Rooflights/Screens
- L20 Doors/Shutters/Hatches

Nationwide Fabricator Network

Once Alu-Timber has been specified, a Nationwide network of approved fabricators ensures the successful completion of projects. Your Alu-Timber advisor can provide fabricators who specialise in commercial, new build, residential, refurbishment or public building work.

Genesis Estimating Alu-Timber Projects

Through our Nationwide network of approved fabricators, The Parkside Group Limited supplies Genesis estimating software. Genesis is a powerful estimating tool; it provides fast, accurate pricing from plans and tenders for the entire product range available from The Parkside Group Limited. Genesis includes the facility to provide section through details which can be exported to CAD so approved fabricators can add detail to design drawings. All approved fabricators are trained in Genesis, ensuring they provide accurate budget pricing and tender returns.



Finishes

Alu-Timber aluminium finishes are available in all RAL, Syntha Pulvin and BS colours. Aluminium profiles are finished to the following specifications: silver, bronze and black anodising AA 25 to BS EN 12373-1 : 2001 or BS 3987. Liquid organic coating to BS 4842 : 1984. Polyester powder coating to BS 6496 : 1984. Polyester powder coated profiles are to a minimum of 60 microns. The timber is produced from sustainable, managed forests, glue laminated and finger jointed in profile lengths, excluding chemical preservative treatment but coated with three coats of lacquer. Other timbers are available, which are subject to similar sustainable treatments.

Materials

Extruded aluminium profiles are of aluminium alloy 6063 T5, T6 to BS EN 12020 and BS EN 755-1: 1997. Gaskets are extruded from E.P.D.M. rubber. The standard timber is Larch from FSC, PEFC accredited sources, any glues or adhesives comply with BS EN204 Category D4.

Guaranteed Longevity

Alu-Timber provides additional reassurance with its guarantees. Due to its traditional aluminium construction the external polyester powder coated frames are guaranteed in a non-marine environment for 25 years. The internal timber is a stable material which has an indefinite life-cycle, the only issue could be de-lamination. To this end the timber is guaranteed for 12 years. The Parkside Group with over forty years of facade systems experience provides a project-by-project design warranty. All of these elements ensure specifiers the highest guarantees in the market.

Hardware, Glazing & Gaskets

Hardware

Alu-Timber utilises a range of hardware such as handles, locks, friction stays and restrictors. Apart from unique components, all Alu-Timber systems utilise hardware selected from standard catalogue items for Euro-groove fitting.



Glazing

Generally, all glazing shall comply with the requirements of BS 6375 and BS 6262: 1982, British Standard Code of Practice for Glazing in Buildings. Glazing beads and gaskets allow for glazing of 28mm units. Depending on the configuration, glazing beads are fitted internally or externally. Drainage of glazing and opening lights is an important aspect of design. Profiles have drainage slots in the glazed recess and rebated areas to ensure ventilation and drainage of the rebates as well as providing a water barrier. Where specified, hermetically sealed double glazed units shall comply with the requirement of BS 5713 : 1979. The specification of hermetically sealed double glazed units shall be as stated in the works section.

Gaskets

Glazing materials are high performance pre-formed non-structural gaskets complying with the requirements of BS 4255, Part 2.

Alu-Timber... it's in the details

Alu-Timber Casement

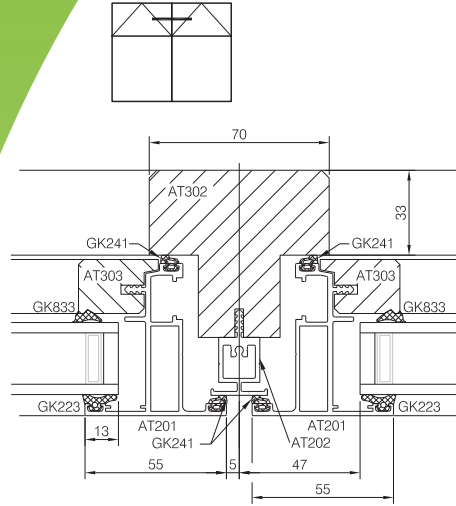

Alu-Timber Casement

General arrangement showing mullion detail with open out vents

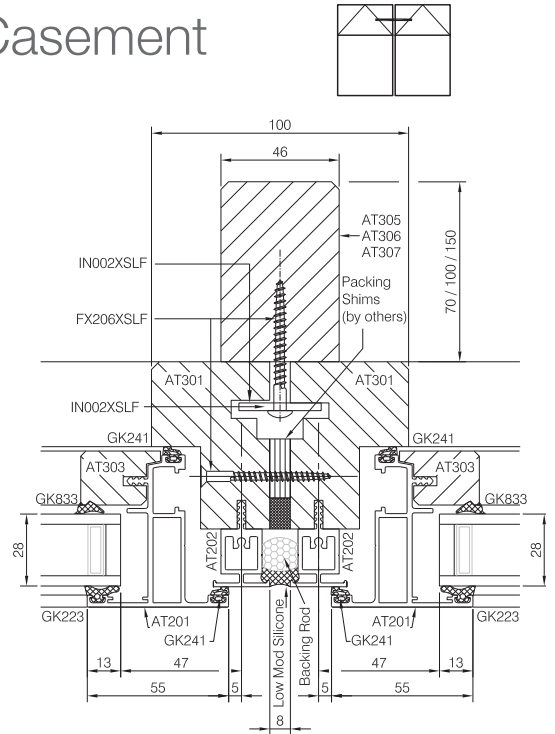

Alu-Timber Casement

General arrangement showing Vent Coupled Windows with Mullion Combined
 $I_{xx} = 1186.97\text{cm}^4$ (70mm),
 $I_{xx} = 4807.6\text{cm}^4$ (150mm)

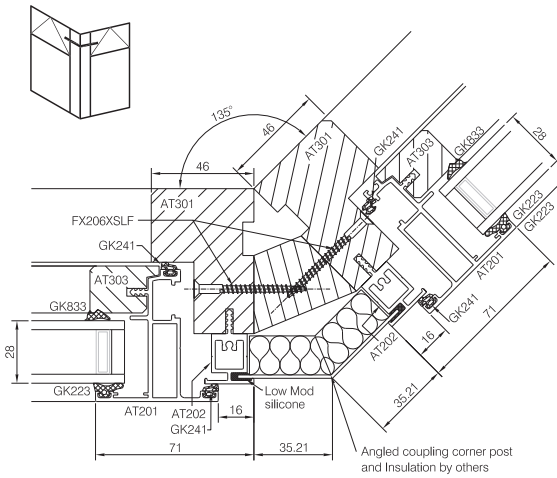

Alu-Timber Casement

General arrangement showing 145 degree bay detail

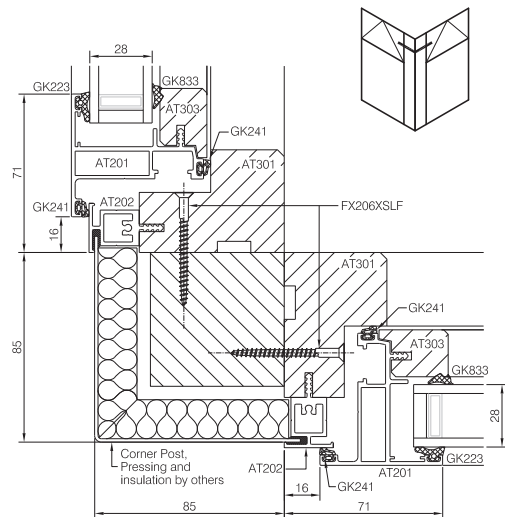
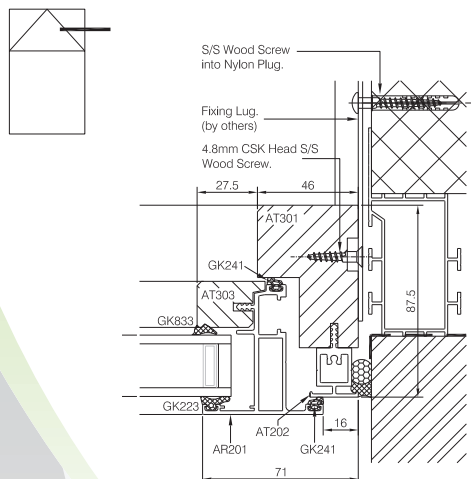

Alu-Timber Casement

General arrangement showing 90 degree external corner detail

Alu-Timber Casement

General arrangement showing jamb detail

Alu-Timber Tilt & Turn

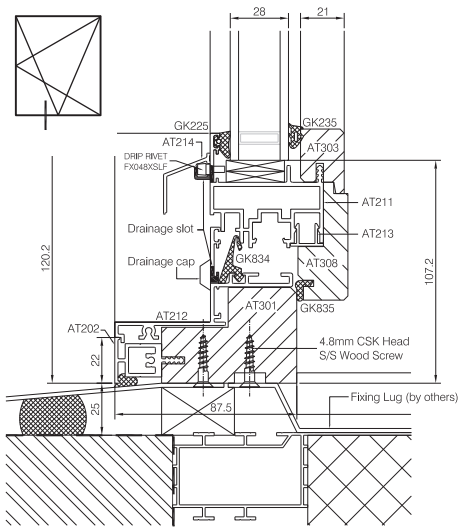

Alu-Timber Tilt & Turn
General arrangement showing window cill detail

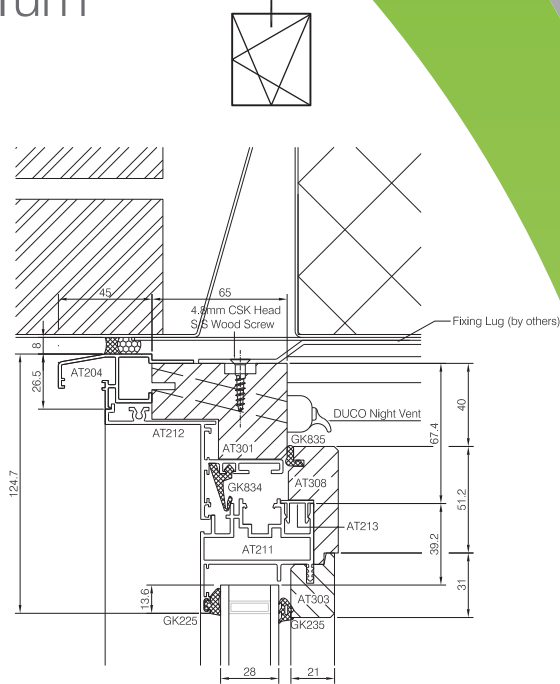

Alu-Timber Tilt & Turn
General arrangement showing window head detail

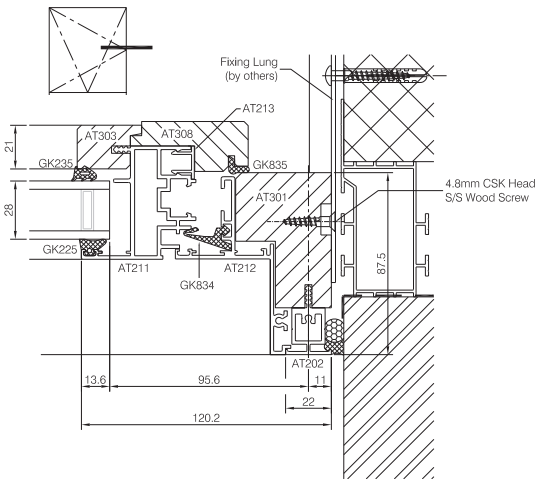

Alu-Timber Tilt & Turn
General arrangement showing jamb detail

Alu-Timber Door

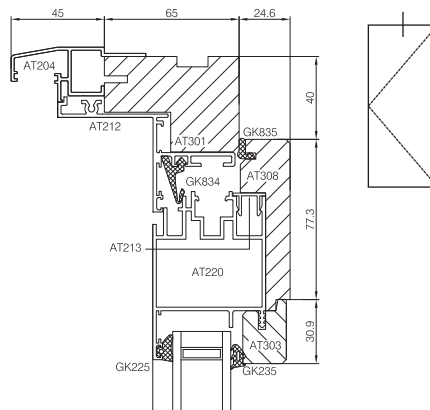

Alu-Timber Door
General arrangement showing
open in door head detail

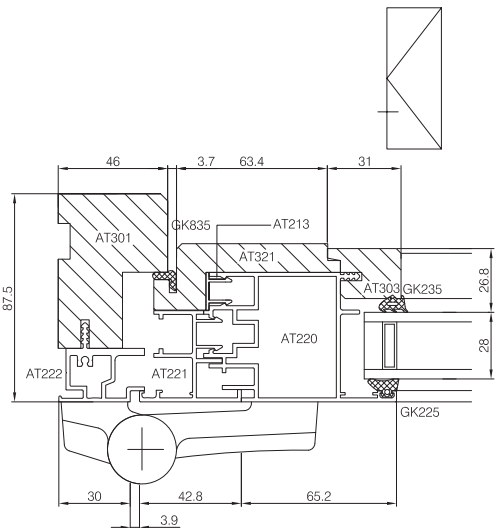

Alu-Timber Door
General arrangement showing open out jamb detail

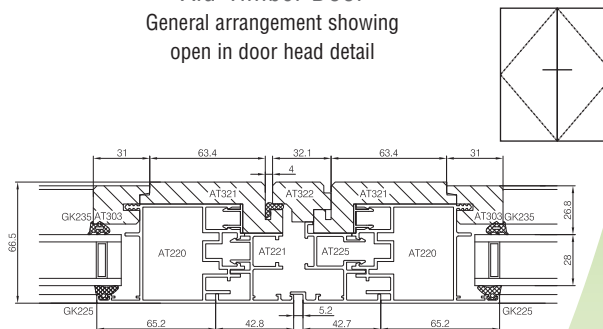

Alu-Timber Door
General arrangement showing
Alu-Timber open out double meeting stile

Alu-Timber Framing

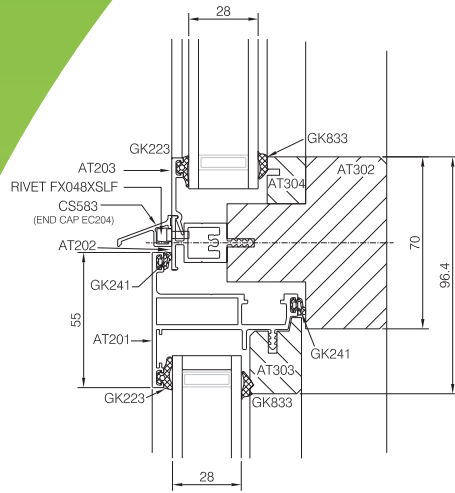

Alu-Timber Framing

General arrangement showing Alu-Timber transom detail

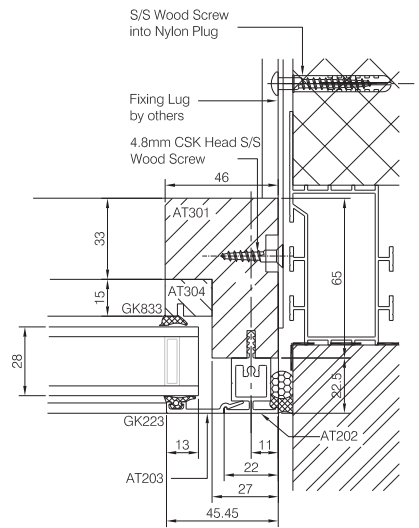

Alu-Timber Framing

General arrangement showing Alu-Timber jamb detail

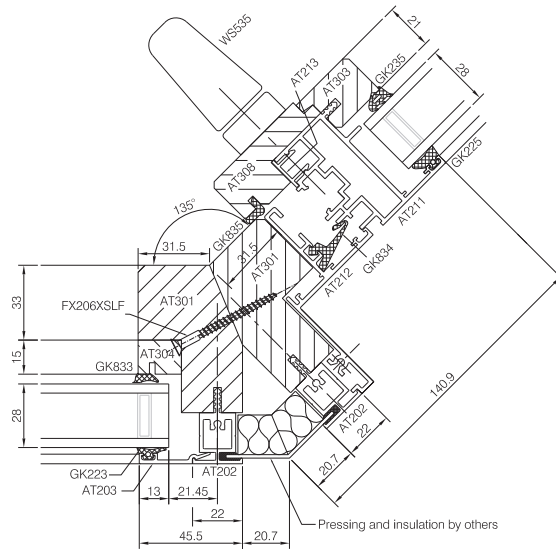

Alu-Timber Framing

General arrangement showing Alu-Timber 135 degree corner with tilt & turn vent

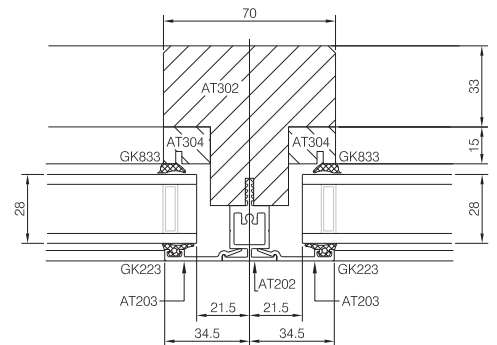

Alu-Timber Framing

General arrangement showing mullion detail

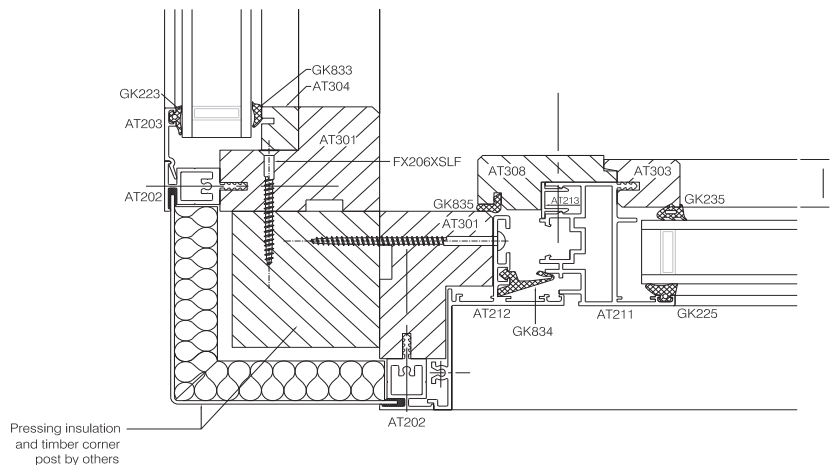

Alu-Timber Framing

General arrangement showing Alu-Timber 90 degree corner with tilt & turn vent

Sustainability

The Parkside Group Limited, have environmental management systems to ISO 14001. All suppliers must comply with our supplier audits to ensure all products are continuously improved to minimise their impact on the environment, actively reducing their carbon foot print.

Alu-Timber

All of the components within Alu-Timber are sourced with the key directive of minimising both waste in their production and their impact on the environment. There are four main elements of Alu-Timbers sustainable strategy.

1. Sustainably Sourced Timber

All engineered timbers (Larch, Softwood, Eucalyptus) are farmed from sustainable managed forests compliant with FSC, PEFC accreditations. However, the cut timber is still a valuable resource and its use must be maximised. With this in mind engineered timbers create minimal wastage. The timber is selected at three different lengths 300mm, 1200mm and 1800mm and finger jointed together to the desired length; this ensures that more of the timber can be used. The timber is laminate bonded together with formaldehyde free polyurethane adhesives and a water soluble environmentally friendly lacquer is applied which is fully comparable with natural wood. If solid timbers, such as Oak, are required, certification from PEFC or FSC ensures the responsible farming and re-planting strategies are used.

2. Aluminium Longevity

Aluminium provides durability, is corrosion resistant and has a high strength to weight ratio meaning that less can be used to create the desired profile. Aluminium is produced from Bauxite, one of the most abundant minerals in the earth's crust. Sustainability concerns are alleviated by the knowledge that we have at least 300 years of known reserves of Bauxite, and this does not allow for the fact that 75% of all aluminium used in construction is from recycled sources.

With an ever increasing proportion of re-cycled material in use, aluminium can be accurately described as the ultimate sustainable material. Producing aluminium is an energy intensive procedure. However, two-thirds of the energy required to extract aluminium is supplied by environmentally friendly, hydroelectric power. Aluminium is polyester powder coated or anodised. With minimal maintenance its design life is almost limitless.

3. Merging Materials to Provide a Design for Life

Alu-Timbers design means that the aluminium completely protects the internal timber, no water can penetrate on to the timber. Even the corner jointing is designed so no raw edges are exposed to the elements. This provides the ultimate in sustainability: longevity, a facade system material that will last for future generations. Alu-Timber has a design life of 40 years.

4. End of Life

All components within Alu-Timber can be reclaimed and have an end of life use. The timber and aluminium can be separated and recycled. The aluminium element is 100% recyclable, with no loss to its properties. The highly developed scrap aluminium industry is evidence of aluminium's end of life high value. Used aluminium is valuable and is easily and endlessly recycled without quality loss. The timber element can be recycled and is traditionally used in the wood chip board industry. Alternatively, it can be chipped and composted or can be used to fire commercial combustion systems in the wood working or lumber industries. Accessories can be stripped down to their residual components and recycled accordingly.



Alu-Timber

Standards

BS EN ISO 14001 :	Comar is an ISO 14001 registered firm, certificate number: EMS 555373
BS EN ISO 9001 :	Comar is an ISO 9001 registered firm, certificate number: BSI: FM553615
BS-EN 755:	Aluminium alloy extrusion
BS EN 485:	Aluminium alloy sheet
BS-EN515:	Aluminium and aluminium alloys – Wrought products temper designations
BS 4255 Part-1 :	Gaskets
BS-EN573-3:	Aluminium and aluminium alloys – Chemical composition – Wrought products – part3
BS-EN755-2:	Aluminium and aluminium alloys – Extruded profiles – part 2: Mechanical properties.
BS-EN755-9:	Aluminium and aluminium alloys – Extruded profiles – part 9 : Profile tolerances.
BS-EN12020-1 :	Aluminium and aluminium alloys – Extruded precision profiles – part1 : inspection and delivery
BS-EN12020-2:	Aluminium and aluminium alloys – Extruded precision profiles – part 2 : tolerances on dimension and form.
BS 4873:	Specification for aluminium alloy windows.
BS6375 Part 1 :	Classification for weather tightness.
BS368:	Method of testing windows
BS 5713:	Hermetically sealed flat double glazed units
BS6262:	Code of practice for glazing of buildings
BS6496:	Specification for powder organic coatings to aluminium alloys for external architectural purposes
BS1615:	Method of specifying anodic oxidation coatings on aluminium and its alloy
BS3987:	Specification for anodic oxide coatings for external architectural purposes
BS6399 Part 2:	Code of practice for wind loads
C.W.C.T.	(Centre for Window & Cladding Technology)
DIN EN 204:2001 :	Classification of thermoplastic wood adhesives for non-structural applications.
BS 644:2009:	Timber Windows. Fully finished factory-assembled windows.

Kitemark BSi Licences:

- KM 578159 - BS 4873 - Systems Supplier Aluminium alloy windows
- KM 578160 - BS 4873/PAS24 - Enhanced security performance of windows for domestic applications
- KM 590092 - PAS 23-1 & PAS 24-1 - System Supplier - General and Enhanced Security Performance Requirements for Door Assemblies
- KM 593756 - BS 4873/PAS24 - Doors System Supplier

Secured by Design Licence Holder



Alu-Timber
Merging Material Solutions



The Parkside Group Ltd, Unit 5, The Willow Centre,
17 Willow Lane, Mitcham, Surrey, CR4 4NX

Tel: +44(0) 20 8685 9685

Fax: +44(0) 20 8646 5096

Email: projects@parksidegroup.co.uk

Web: www.alu-timber.co.uk